

NOTES:

- 1) 80 DUROMETER BLACK PVC (1.370 G/CM<sup>3</sup>)
- 2) CLOSED CELL EPDM SPONGE RUBBER (0.380 G/CM<sup>3</sup>)
- 3) 1" STAMPED STEEL CARRIER (0.046 LB/FT)
- 4) CYANOACRYLATE ADHESIVE

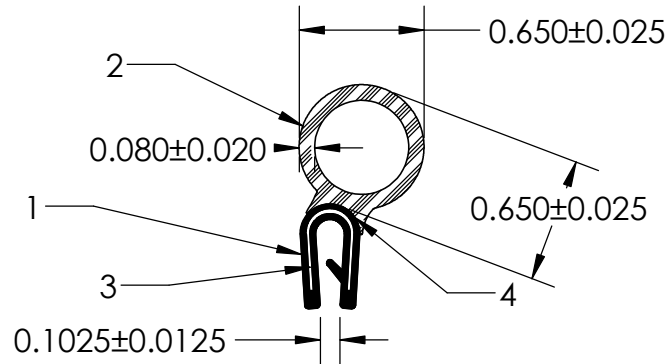
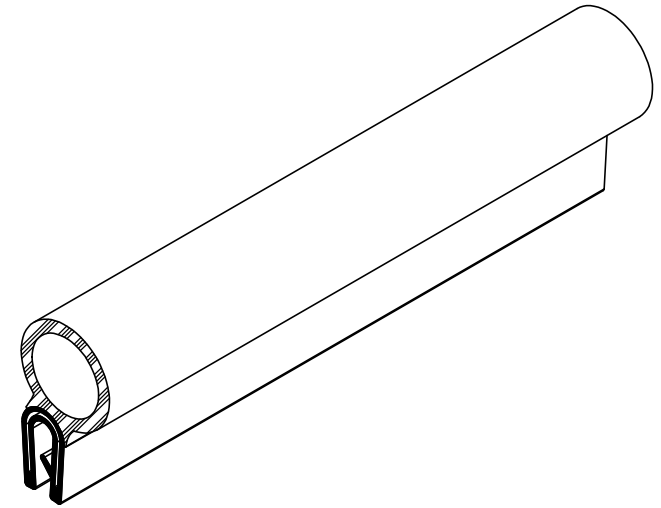

**UNI-GRIP, INC.**

9823 STATE ROUTE 53 N  
UPPER SANDUSKY, OHIO 43351

REVISION BLOCK				PROPRIETARY AND CONFIDENTIAL:	UNLESS OTHERWISE SPECIFIED:	TITLE:				
REV.	DATE	R. By	CHANGES MADE	THE INFORMATION CONTAINED IN THIS DRAWING IS THE SOLE PROPERTY OF UNI-GRIP, INC. ANY REPRODUCTION IN PART OR AS A WHOLE WITHOUT THE WRITTEN PERMISSION OF UNI-GRIP, INC. IS PROHIBITED.	DIMENSIONS ARE IN INCHES TOLERANCES PER ARPM CLASS 3	SD-120-AAT-OFFSET				
A										
B					WEIGHT	0.126 LB/FT				
C					ASTM D1056	2A2	SIZE	DWG. NO.	REV	
D					DOCUMENT CONTROL NUMBER	ASTM D2000	<b>A</b>	UG-1-GL-1000-FS-046		
E				UG-1-EN-001-FR-(080918)	N/A	DR. BY	C. VENT	DATE	10/13/2020	SHEET 1 OF 1
P:\Engineering\Prints\Master Prints\Glue Line\SD-120-AAT-OFF SET UG-1GL-1000-FS-046				SCALE:	1:1					